



776026 CARBON STEEL

Válvula de bola Wafer PN16 con brida en acero al carbono bruñido A105, desviador de flujo, con bola L o T de tres vías con 2 juntas.

A105 Antistatic Device "L".

Especificaciones técnicas

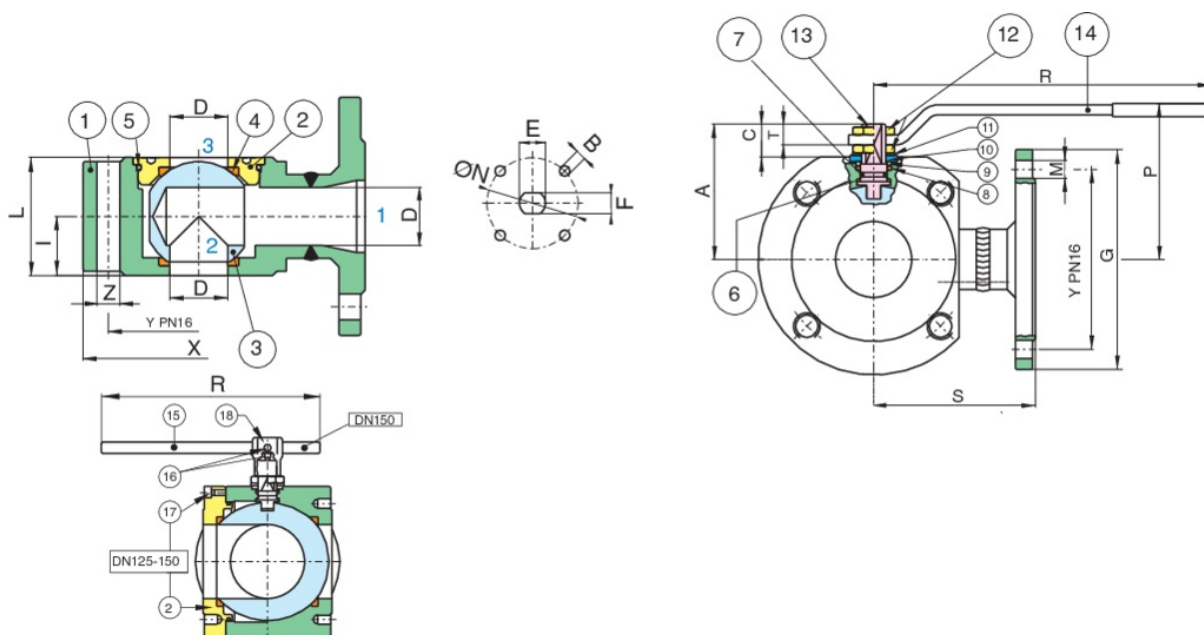

POSICIÓN	NOMBRE DE LA PIEZA	MATERIAL	N.º PIEZAS
1	CUERPO	ASTM A105/A352-LCB	1
2	BRIDA	ASTM A105/A352-LCB	1
3	TERMINAL	ASTM-A105	1
4	ASIENTO ESFERA	PTFE	2
5	BOLA	A351-CF8M	1
6	EJE	A479-TP304	1
7	PALANCA	A37+Z/P	1
8	90° STOP	AISI 430	2
10	EMPAQUETADURA	TFM	1
9	MANGUITO PRENSAESTOPAS	A37+Z/P	1
11	ASIENTO EJE	PTFE	1
12	MUELLE CONTENEDOR	51CRV4	2
13	TUERCA	6S+Z/P	1-2
14	O-RING	FKM	1
15	O-RING	FKM	1
16	TORNILLO	8.8+Z/P	2
17	CUERPO PALANCA	EN-GJL 250	1
18	PALANCA	S275J2H	1
19	ARANDELA DESENROSCADO	AISI 316	1
20	TORNILLO	8.8+Z/P	7

TAMAÑO	DN	CÓDIGO	X	Y	Z	I	L	R	P	A	C	G	M	D	S	E	F	ØN	B	KV(L)	PN	KG	T
1/2"	15	77602604	89	65	4xM12	20	40	132	83,5	47	15,5	89	4xØ14	10	76	10	7	32	4xM5	2,8	16	2,3	8,5
3/4"	20	77602605	99	75	4xM12	20	40	132	86	49,5	13,5	99	4xØ14	15	82	10	7	32	4xM5	5,2	16	2,9	8,5
1"	25	77602606	109	85	4xM12	23	46	175	99	59	18	109	4xØ14	20	86	12	8	42	4xM5	9,2	16	3,9	10,5
1"1/4	32	77602607	130	100	4xM16	29	58	175	104	64	15,5	119	4xØ18	25	105	12	8	42	4xM5	14,4	16	6,2	10,5
1"1/2	40	77602608	140	110	4xM16	35,5	71	251	105	78	24,5	127	4xØ18	32	125	16	10	50	4xM6	25,9	16	8,8	13,5
2"	50	77602610	160	125	4xM16	41	82	251	110	84,5	23,5	150	4xØ18	40	120	16	10	50	4xM6	40,4	16	12,27	12
2"1/2	65	77602612	180	145	4xM16	53	106	321	128	104,5	28	179	4xØ18	50,2	125	20	14	70	4xM8	63,2	16	19,8	18
3"	80	77602614	200	160	8xM16	61	122	321	136	113	28	190	8xØ18	64	150	20	14	70	4xM8	115,8	16	29,00	18
4"	100	77602618	220	180	8xM16	76	152	381,5	156	136	34,5	233	8xØ18	76	159	24	18	102	4xM10	163,2	16	40,1	22
5"	125	77602619	250	210	8xM16	98	196	381,5	179	159	29,5	255	8xØ18	100	190	24	18	102	4xM10	282,6	16	63,5	22
6"	150	77602620	306	240	8xM20	116	242	700	266	201	48	280	8xØ22	125	210	42	30	125	4xM12	441,6	16	113,5	29

Certificaciones



TUV



ATEX