

720185



Full bore flanged ball valve PN16, in blued carbon steel ASTM A105/A352-LCB.

ASTM-A105 Fire Safe.

V-Ball option



Technical specifications

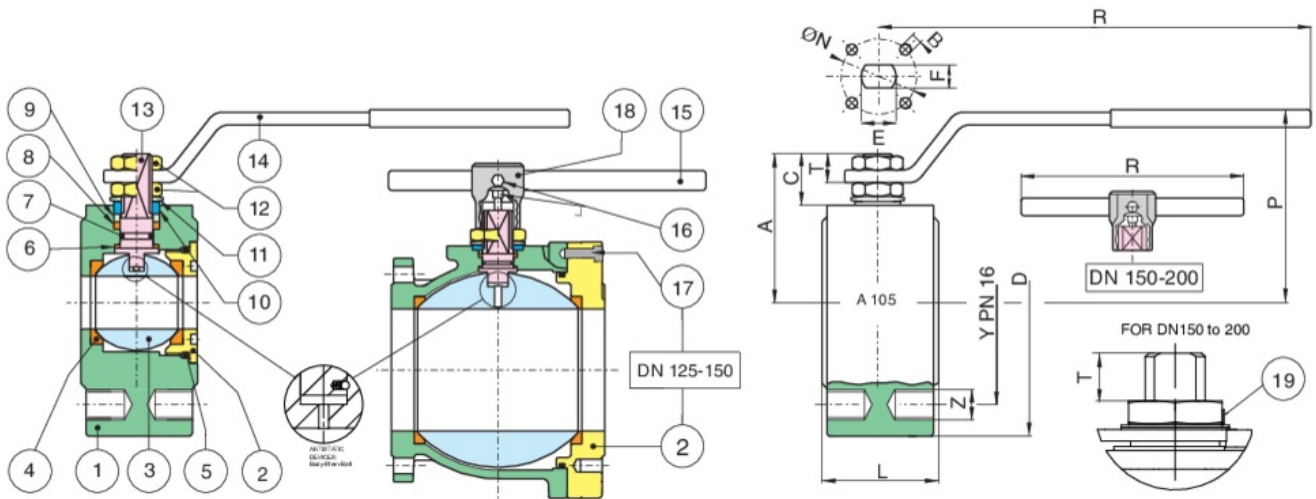

POSITION	PART NAME	MATERIAL	N.° PIECES
1	BODY	ASTM A105/A352-LCB	1
2	END CONNECTION	ASTM A105/A352-LCB	1
3	BALL	A351-CF8/A479-TP304	1
4	BALL SEAT	PTFE CARBOGRAFITE - CARBON FILLED PTFE	2
5	O-RING	FKM (VITON)	1
6	ANTIFRICTION RING	PTFE CARBOGRAFITE - CARBON FILLED PTFE	1
7	O-RING	FKM (VITON)	1
8	STEM SEAT	PTFE CARBOGRAFITE - CARBON FILLED PTFE	1
9	PACKING GLAND	A37+Z/P	1
10	90° STOP	AISI 430 (DN15-DN50) A37+Z-P (DN65-DN200)	2-1
11	SPRING WASHER	51CrV4+Z/P	2
12	NUT	6S+Z/P	2-1
13	STEM	A479-TP304	1
14	HANDLE	A37+Z/P	1
15	HANDLE DN 150	S275J2H	1
16	SCREW DN150	8.8+Z/P	2
17	SCREW DN150	8.8+Z/P	8-12
18	BODY HANDLE DN 150	EN-GJL 250	1
19	UNSCREWING GROWER DN150-DN200	AISI 316	1

SIZE	DN	CODE	D	Y	Z	L	R	P	A	C	T	E	F	ØN	B	KV	PN	KG
1/2"	15	72018504	90	65	4xM12	35	131	65	47	15,5	9	10	7	32	4xM5	19,2	16	1,40
3/4"	20	72018505	100	75	4xM12	40	131	69	51,5	15,5	9	10	7	32	4xM5	35	16	1,90
1"	25	72018506	110	85	4xM12	46	174	80	61	19,5	11	12	8	42	4xM5	64,5	16	2,70
1"1/4	32	72018507	130	100	4xM16	54	174	84	34,5	16,5	11	12	8	42	4xM5	103,8	16	4,20
1"1/2	40	72018508	140	110	4xM16	63,5	250	102	78	24,5	13	16	10	50	4xM6	174	16	6,30
2"	50	72018510	150	125	4xM16	82	250	111	87	25	13	16	10	50	4xM6	301,3	16	8,70
2"1/2	65	72018512	175	145	4xM16	103	321	128	104,5	28	18	20	14	70	4xM8	545,7	16	15,50
3"	80	72018514	190	160	8xM16	122	321	138	115	28,5	18	20	14	70	4xM8	872,5	16	20,50
4"	100	72018518	220	180	8xM16	152	381	156	137	34,5	22	24	18	102	4xM10	1363	16	34,20
5"	125	72018519	250	210	8xM16	196	381	178	159	34	22	24	18	102	4xM10	2360	16	40,7
6"	150	72018520	300	240	8xM20	232	700	266	201,5	51,5	30	42	30	125	4xM12	3671	16	66,8

Certifications

F.E. TESTED
ISO15848-1

F.E. TESTED ISO15848-1



TUV

SIL 3

SIL 3



ATEX FIRE-SAFE (On request)