

WAFFER PN16

720060



Full bore flanged ball valve PN16, in blued carbon steel ASTM A105/A352-LCB.

ASTM-A105 ANSI 150 Metric zinc plated.

V-Ball option



Technical specifications

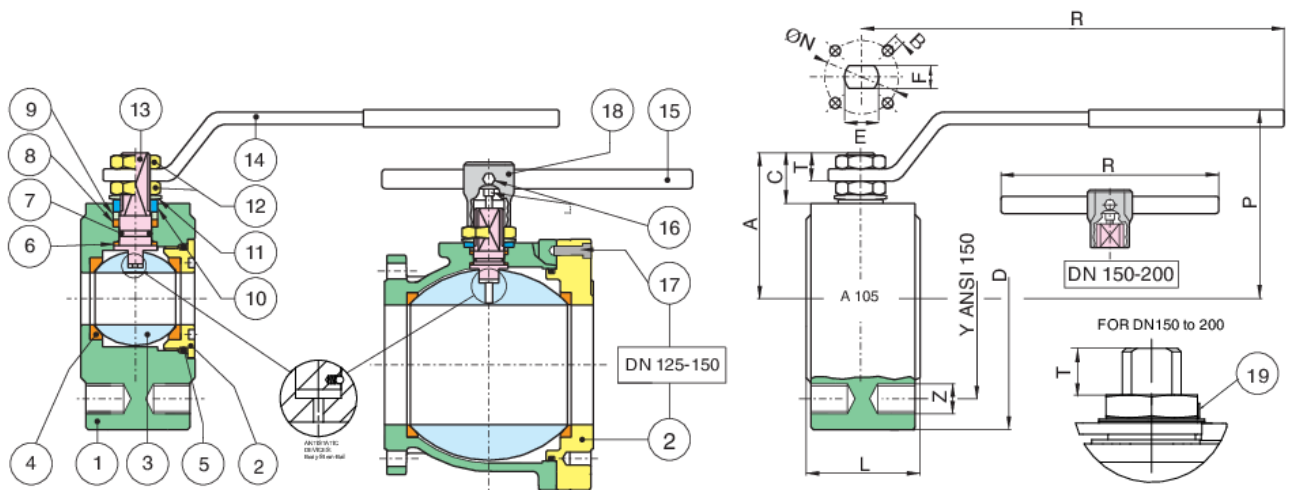

POSITION	PART NAME	MATERIAL	N.° PIECES
1	BODY	ASTM A105/A352-LCB	1
2	END CONNECTION	ASTM A105/A352-LCB	1
3	BALL	A351-CF8/A479-TP304	1
4	BALL SEAT	PTFE	2
5	O-RING	FKM (VITON)	1
6	ANTIFRICTION RING	TFM	1
7	O-RING	FKM (VITON)	1
8	STEM SEAT	PTFE	1
9	PACKING GLAND	A37+Z/P	1
10	90° STOP	AISI 430 (DN15-DN50) A37+Z-P (DN65-DN200)	2-1
11	SPRING WASHER	51CrV4+Z/P	2
12	NUT	6S+Z/P	2-1
13	STEM	A479-TP304	1
14	HANDLE	A37+Z/P	1
15	HANDLE DN 150	S275J2H	1
16	SCREW DN150	8.8+Z/P	2
17	SCREW DN125 - DN150	8.8+Z/P	8
18	BODY HANDLE DN150	EN-GJL 250	1
19	UNSCREWING GROWER DN150	AISI 316	1

SIZE	DN	CODE	D	Y	Z	L	R	P	A	C	T	E	F	ØN	B	KV	PN	KG
1/2"	15	72006004	90	60,5	4xM14	35	131	65	47	15,5	9	10	7	32	4xM5	19,2	20	1,4
3/4"	20	72006005	100	69,8	4xM14	40	131	69	51,5	15,5	9	10	7	32	4xM5	35	20	1,9
1"	25	72006006	110	79,2	4xM14	46	174	80	61	19,5	11	12	8	42	4xM5	64,5	20	2,70
1"1/4	32	72006007	118	88,9	4xM14	54	174	84	64,5	16,5	11	12	8	42	4xM5	103,8	20	3,70
1"1/2	40	72006008	127	98,6	4xM14	63,5	250	102	78	24,5	13	16	10	50	4xM6	174	20	5,40
2"	50	72006010	150	120,6	4xM16	82	250	111	87	25	13	16	10	50	4xM6	301,3	20	8,80
2"1/2	65	72006012	175	139,7	4xM16	103	321	128	104,5	28	18	20	14	70	4xM8	545,7	20	15,60
3"	80	72006014	190	152,4	4xM16	122	321	138	115	28,5	18	20	14	70	4xM8	872,5	20	20,80
4"	100	72006018	223	190,5	8xM16	152	381	156	137	34,5	22	24	18	102	4xM10	1363	20	36,00
5"	125	72006019	250	215,9	8xM20	196	381	178	159	34	22	24	18	102	4xM10	2360	20	40,7
6"	150	72006020	280	241,3	8xM20	232	700	266	201,5	51,5	30	42	30	125	4xM12	3671	20	66,8

Certifications

F.E. TESTED
ISO15848-1

F.E. TESTED ISO15848-1



TUV

SIL 3

SIL 3



ATEX FIRE-SAFE (On request)