

720017



Full bore flanged ball valve ANSI 150, in blued carbon steel ASTM A105/A352-LCB.

ASTM-A105 ANSI 150 UNC.

V-Ball option



Technical specifications

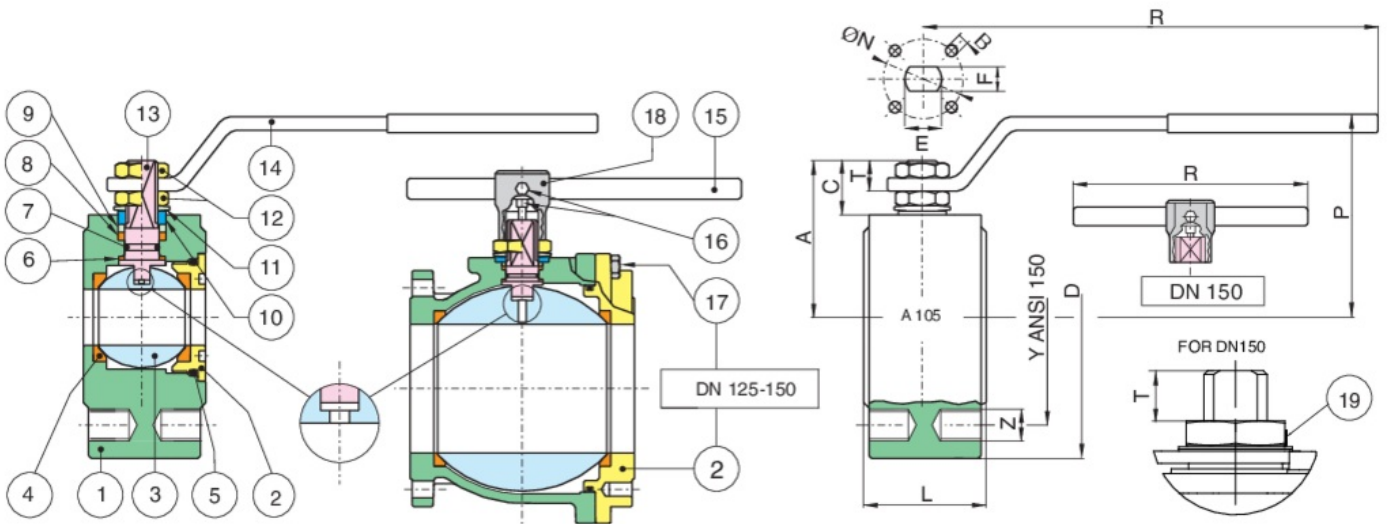

POSITION	PART NAME	MATERIAL	N.° PIECES
1	BODY	ASTM A105/A352-LCB	1
2	END CONNECTION	ASTM A105/A352-LCB	1
3	BALL	A351-CF8/A479-TP304	1
4	BALL SEAT	PTFE	2
5	O-RING	FKM (VITON)	1
6	ANTIFRICTION RING	TFM	1
7	O-RING	FKM (VITON)	1
8	STEM SEAT	PTFE	1
9	PACKING GLAND	A37+Z/P	1
10	90° STOP	AISI 430 (DN15-DN50) A37+Z-P (DN65-DN200)	2-1
11	SPRING WASHER	51CrV4+Z/P	2
12	NUT	6S+Z/P	2-1
13	STEM	A479-TP304	1
14	HANDLE	A37+Z/P	1
15	HANDLE DN 150	S275J2H	1
16	SCREW DN150	8.8+Z/P	2
17	SCREW DN125 - DN150	8.8+Z/P	8
18	BODY HANDLE DN150	EN-GJL 250	1
19	UNSCREWING GROWER DN150	AISI 316	1

SIZE	DN	CODE	D	Y	Z	L	R	P	A	C	T	E	F	ØN	B	KV	PN	KG
1/2"	15	72001704	90	60,5	4x1/2"	35	131	65	47	15,5	9	10	7	32	4xM5	19,2	20	1,4
3/4"	20	72001705	100	69,8	4x1/2"	40	131	69	51,5	15,5	9	10	7	32	4xM5	35	20	1,9
1"	25	72001706	110	79,2	4x1/2"	46	174	80	61	17	11	12	8	42	4xM5	64,5	20	2,70
1"1/4	32	72001707	118	88,9	4x1/2"	54	174	84	64,5	15	11	12	8	42	4xM5	103,8	20	3,70
1"1/2	40	72001708	130	98,6	4x1/2"	63,5	250	102	78	24,5	13	16	10	50	4xM6	174	20	5,40
2"	50	72001710	152	120,6	4x5/8"	82	250	111	87	25	13	16	10	50	4xM6	301,3	20	8,80
2"1/2	65	72001712	178	139,7	4x5/8"	103	321	128	104,5	25	18	20	14	70	4xM8	545,7	20	15,60
3"	80	72001714	190	152,4	4x5/8"	122	321	138	115	28,5	18	20	14	70	4xM8	872,5	20	20,80
4"	100	72001718	220	190,5	8x5/8"	152	381	156	137	34,5	22	24	18	102	4xM10	1363,3	20	36,00
5"	125	72001719	250	215,9	8x3/4"	196	381	178	159	34	22	24	18	102	4xM10	2360,3	20	40,7
6"	150	72001720	280	241,3	8x3/4"	232	700	266	201,5	51,5	30	42	30	125	4xM12	3671,1	20	66,8

Certifications

F.E. TESTED
ISO15848-1

F.E. TESTED ISO15848-1



TUV

SIL 3

SIL 3



ATEX FIRE-SAFE (On request)