

WAFER PN16

720015



Full bore flanged ball valve PN16, in blued carbon steel ASTM A105/A352-LCB.

ASTM-A105 Seats PTFE + fiberglass.

V-Ball option



Technical specifications

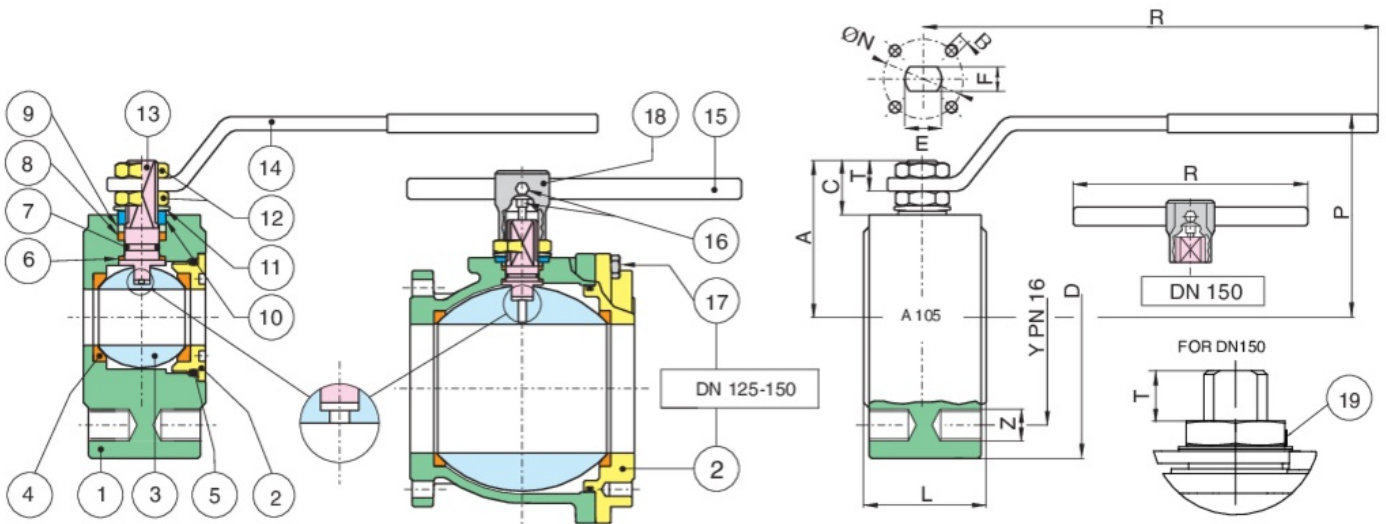

POSITION	PART NAME	MATERIAL	N.° PIECES
1	BODY	ASTM A105/A352-LCB	1
2	END CONNECTION	ASTM A105/A352-LCB	1
3	BALL	A351-CF8/A479-TP304	1
4	BALL SEAT	PTFE CARICATO VETRO - GLASS FILLED PTFE	2
5	O-RING	FKM (VITON)	1
6	ANTIFRICTION RING	TFM	1
7	O-RING	FKM (VITON)	1
8	STEM SEAT	PTFE	1
9	PACKING GLAND	A37+Z/P	1
10	90° STOP	AISI 430 (DN15-DN50) A37+Z-P (DN65-DN200)	2-1
11	SPRING WASHER	51CrV4+Z/P	2
12	NUT	6S+Z/P	2-1
13	STEM	A479-TP304	1
14	HANDLE	A37+Z/P	1
15	HANDLE DN 150	S275J2H	1
16	SCREW DN150	8.8+Z/P	2
17	SCREW	8.8+Z/P	8
18	BODY HANDLE DN 150	EN-GJL 250	1
19	UNSCREWING GROWER DN150	AISI 316	1

SIZE	DN	CODE	D	Y	Z	L	R	P	A	C	T	E	F	ØN	B	KV	PN	KG
1/2"	15	72001504	90	65	4xM12	35	131	65	47	15,5	9	10	7	32	4xM5	19,2	16	1,40
3/4"	20	72001505	100	75	4xM12	40	131	69	51,5	15,5	9	10	7	32	4xM5	35	16	1,90
1"	25	72001506	110	85	4xM12	46	174	80	61	19,5	11	12	8	42	4xM5	64,5	16	2,70
1"1/4	32	72001507	130	100	4xM16	54	174	84	65,5	16,5	11	12	8	42	4xM5	103,8	16	4,20
1"1/2	40	72001508	140	110	4xM16	63,5	250	102	78	24,5	13	16	10	50	4xM6	174	16	6,30
2"	50	72001510	150	125	4xM16	82	250	111	87	25	13	16	10	50	4xM6	301,3	16	8,70
2"1/2	65	72001512	175	145	4xM16	103	321	128	104,5	28	18	20	14	70	4xM8	545,7	16	15,50
3"	80	72001514	190	160	8xM16	122	321	138	115	28,5	18	20	14	70	4xM16	872,5	16	20,50
4"	100	72001518	220	180	8xM16	152	381	156	137	34,5	22	24	18	102	4xM10	1363,3	16	34,20
5"	125	72001519	250	210	8xM16	196	381	178	159	34	22	24	18	102	4xM10	2360,3	16	40,50
6"	150	72001520	300	240	8xM20	232	700	266	201,5	51,5	30	42	30	125	4xM12	3671,1	16	66,20

Certifications

F.E. TESTED
ISO15848-1

F.E. TESTED ISO15848-1



TUV

SIL 3

SIL 3



ATEX FIRE-SAFE (On request)