



776005 CARBON STEEL

Flansch-Kugelhahn PN16 aus brüniertem Stahl A105, 3 Wege mit L- oder T-Bohrung Kugel mit 2 Dichtungen. Mit reduziertem Durchgang.

A105 ANSI 150 metrisch "L".

Technische Spezifikationen

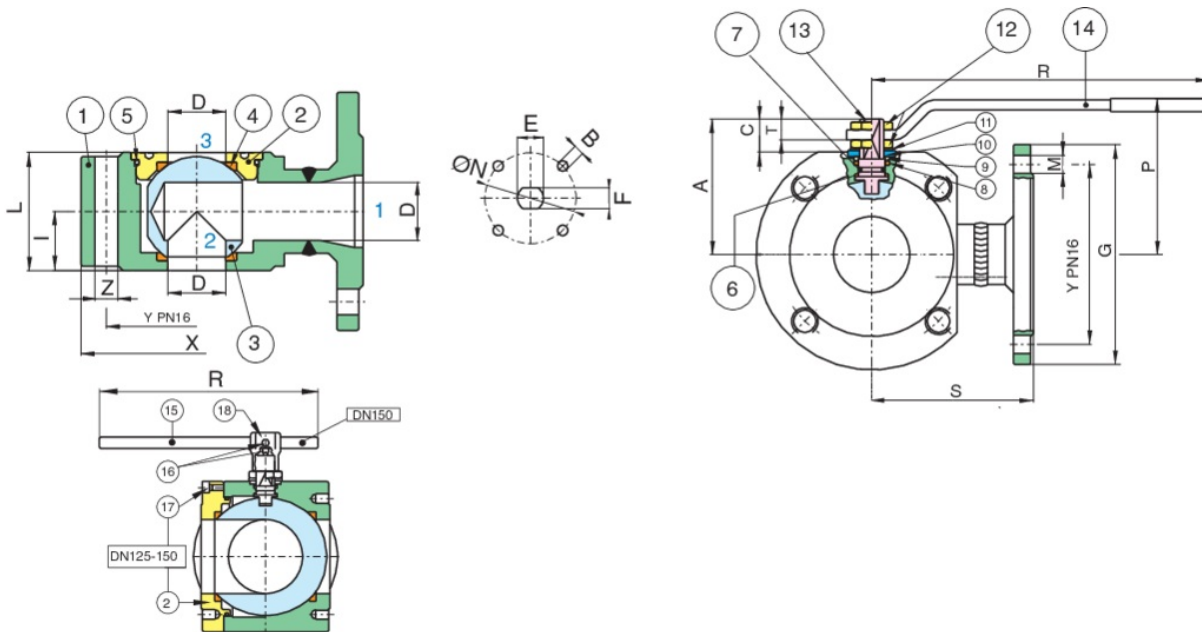

POSITION	TEILNAME	MATERIAL	NR. STÜCK
1	GEHÄUSE	ASTM A105	1
2	FLANSCH	ASTM A105	1
3	RING	ASTM-A105	1
4	KUGELDICHTUNG	PTFE	2
5	KUGEL	A351-CF8M	1
6	SPINDEL	A479-TP304	1
7	HANDHEBEL	A37+Z/P	1
8	90° STOP	AISI 430	2
9	BUCHSE	A37+Z/P	1
10	SPINDELSCHEIBE	TFM	1
11	SPINDELDICHTUNG	PTFE	1
12	TELLERFEDER	51CRV4	2
13	MUTTER	6S+Z/P	1-2
14	O-RING	FKM	1
15	O-RING	FKM	1
16	SCHRAUBE	8.8+Z/P	1
17	BODY HANDLE	EN-GJL 250	1
18	HANDHEBEL	S275J2H	1
19	SICHERUNGSSCHEIBE	AISI 316	1
20	SCHRAUBE	8.8+Z/P	7

GRÖSSE	DN	CODE	X	Y	Z	I	L	R	P	A	C	G	M	D	S	E	F	ØN	B	KV(L)	PN	KG	T
1/2"	15	77600504	89	60,5	4xM14	20	40	132	83,5	47	15,5	89	4xØ16	10	76	10	7	32	4xM5	2,8	20	1,9	8,5
3/4"	20	77600505	99	69,8	4xM14	20	40	132	86	49,5	13,5	99	4xØ16	15	80,5	10	7	32	4xM5	5,2	20	2,5	8,5
1"	25	77600506	109	79,2	4xM14	23	46	175	99	59	18	109	4xØ16	20	86	12	8	42	4xM5	9,2	20	3,5	10,5
1"1/4	32	77600507	119	88,9	4xM14	29	58	175	104	64	15,5	119	4xØ16	25	100	12	8	42	4xM5	14,4	20	5,1	10,5
1"1/2	40	77600508	130	98,6	4xM14	35,5	71	251	105	78	24,5	127	4xØ16	32	105	16	10	50	4xM6	25,9	20	7,5	13,5
2"	50	77600510	155	120,6	4xM16	41	82	251	100	84,5	23,5	150	4xØ18	40	120	16	10	50	4xM6	40,4	20	10,3	12
2"1/2	65	77600512	179	139,7	4xM16	53	106	321	128	104,5	28	179	4xØ18	50,2	125	20	14	70	4xM8	63,2	20	19,6	18
3"	80	77600514	190	152,4	4xM16	61	122	321	136	113	28	190	4xØ18	64	150	20	14	70	4xM8	115,8	20	24,8	18
4"	100	77600518	235	190,5	8xM16	76	152	382	156	136	34,5	233	8xØ18	76	159	24	18	102	4xM10	163,2	20	46,3	22
5"	125	77600519	259	216	8xM20	98	196	382	179	159	29,5	255	8xØ22	100	190	24	18	102	4xM10	282,6	20	69,00	22
6"	150	77600520	305	241,5	8xM20	116	242	700	266	201	48	280	8xØ22	125	210	42	30	125	4xM12	441,6	20	115,5	29

Zertifizierungen



TUV



ATEX